

PARTS LIST			
NO.	TITLE	MATERIAL	QTY.
1	Sturt Narrow Bench GA		1
2	Threaded Rod M12x160	Stainless Steel	4
3	Washer-M12	Stainless Steel	4
4	Hex Nut-M12	Stainless Steel	8

ISSUE	DESCRIPTION	DRAWN	DATE
A	Initial Release	TW	21/06/2018
B	changed leg	TW	24/10/2018

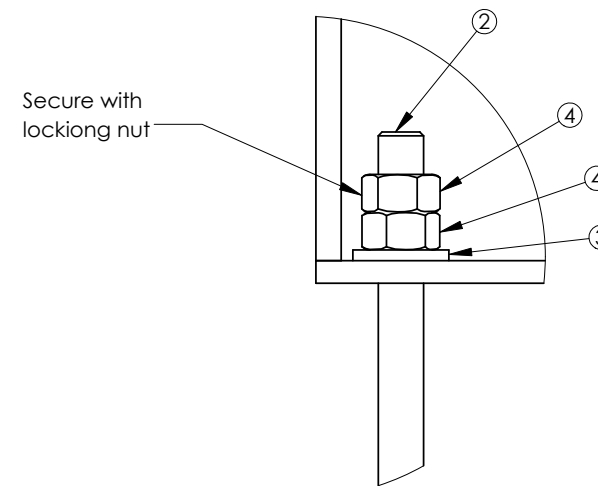
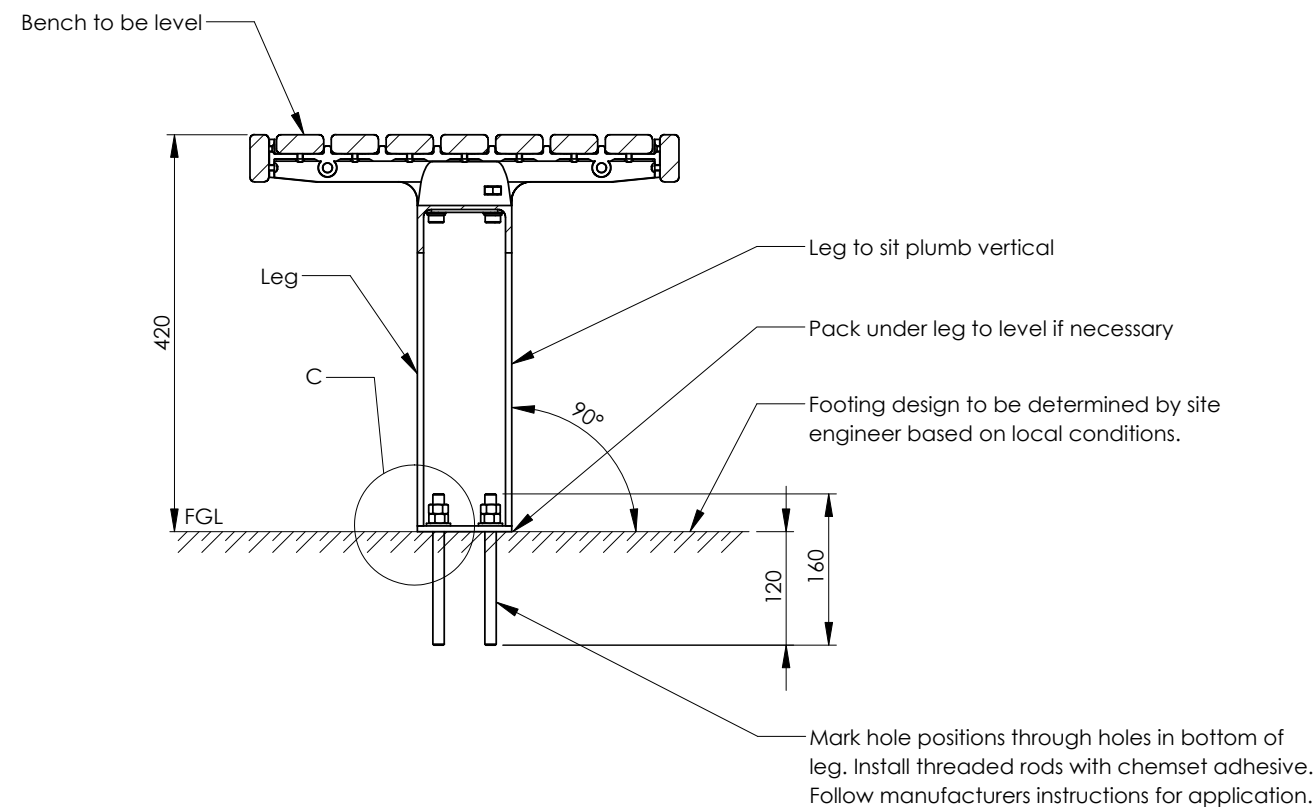
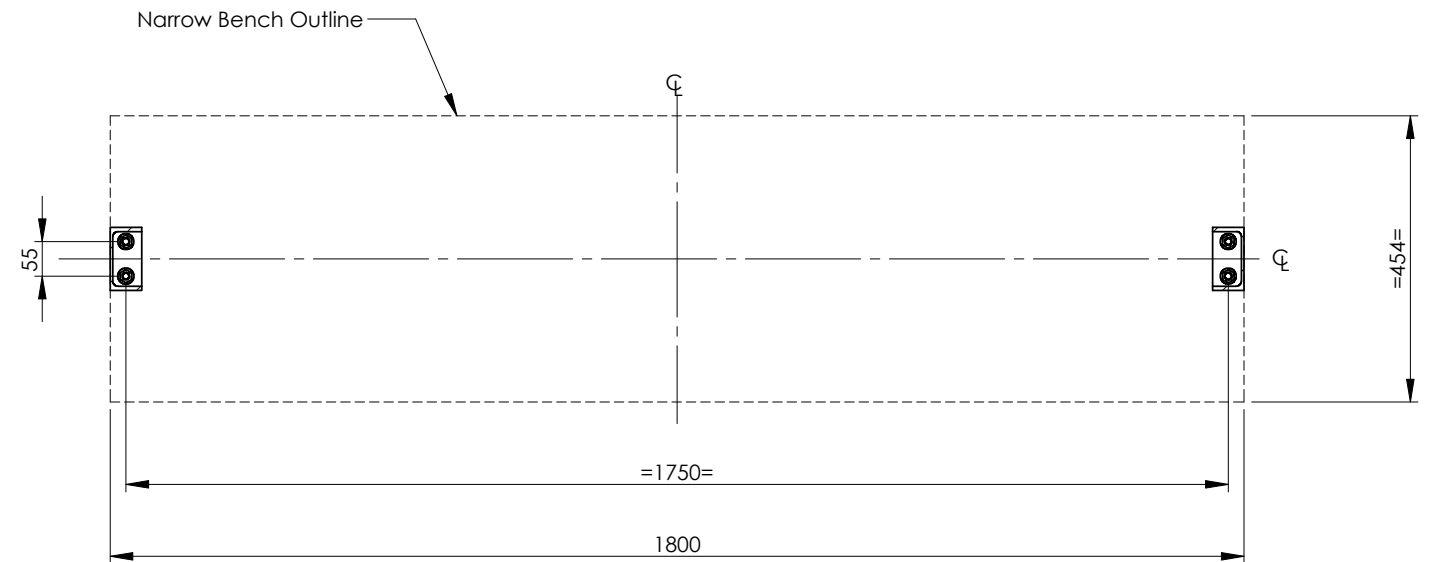

- GENERAL NOTES:
- All dimensions in millimetres unless otherwise shown.
 - Linear Tolerances:
 x ± 1.0
 x.x ± 0.5
 x.xx ± 0.1
 Angular Tolerances:
 ±0.5°
 - No deviation from drawing will be accepted without prior written approval.
 - Do not scale from drawings. Use dimensions provided if this is insufficient or ambiguous contact Mos for clarification

Title:
Surface Installation

Product:
Sturt Narrow Bench

Dwg No: 1046-701 Date Drawn: 27/10/2018 Sheet No: 1 of 1 Scale: 1:12 Sheet: A3



PARTS LIST			
NO.	TITLE	MATERIAL	QTY.
1	Sturt Table GA		1
2	Threaded Rod M12x160	Stainless Steel	4
3	Washer-M12	Stainless Steel	4
4	Hex Nut-M12	Stainless Steel	8

ISSUE	DESCRIPTION	DRAWN	DATE
A	Initial Release	TW	21/06/2018
B	changed leg	TW	24/10/2018

Table to be level

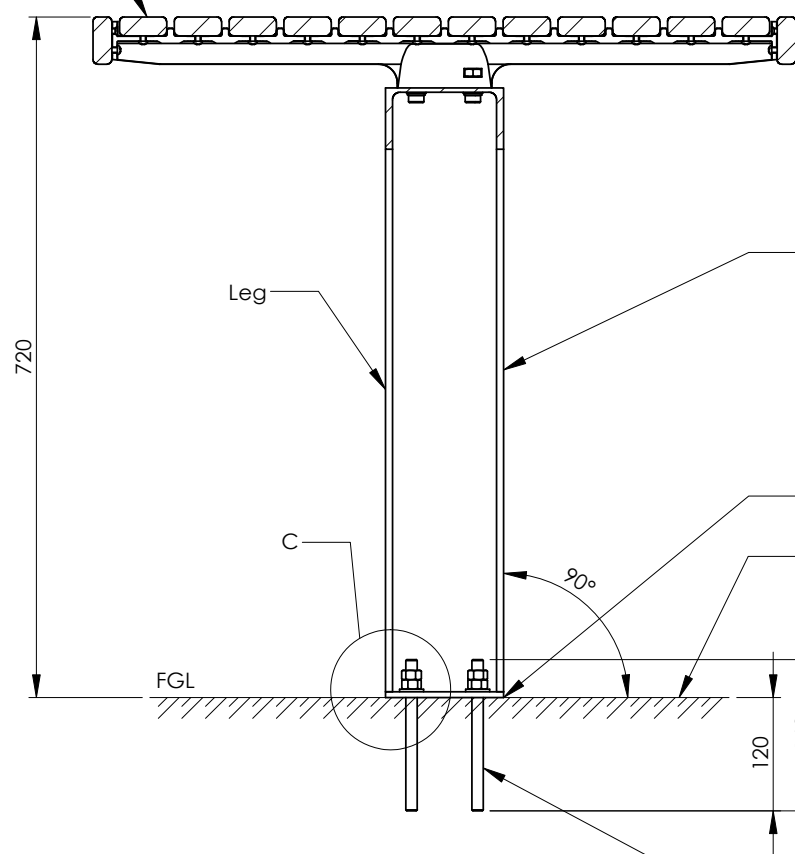

Mark hole positions through holes in bottom of leg. Install threaded rods with chemset adhesive. Follow manufacturers instructions for application.

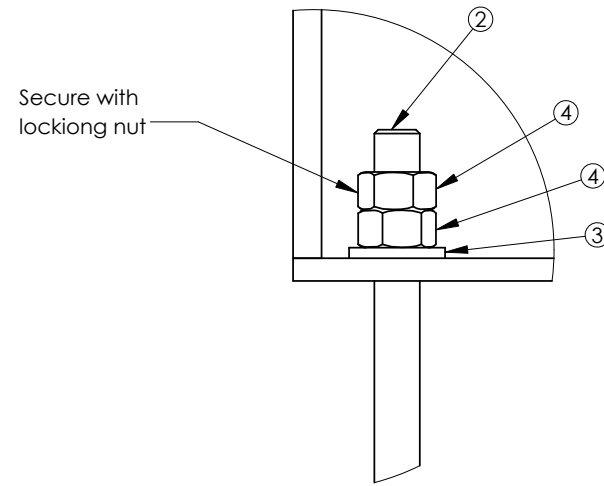
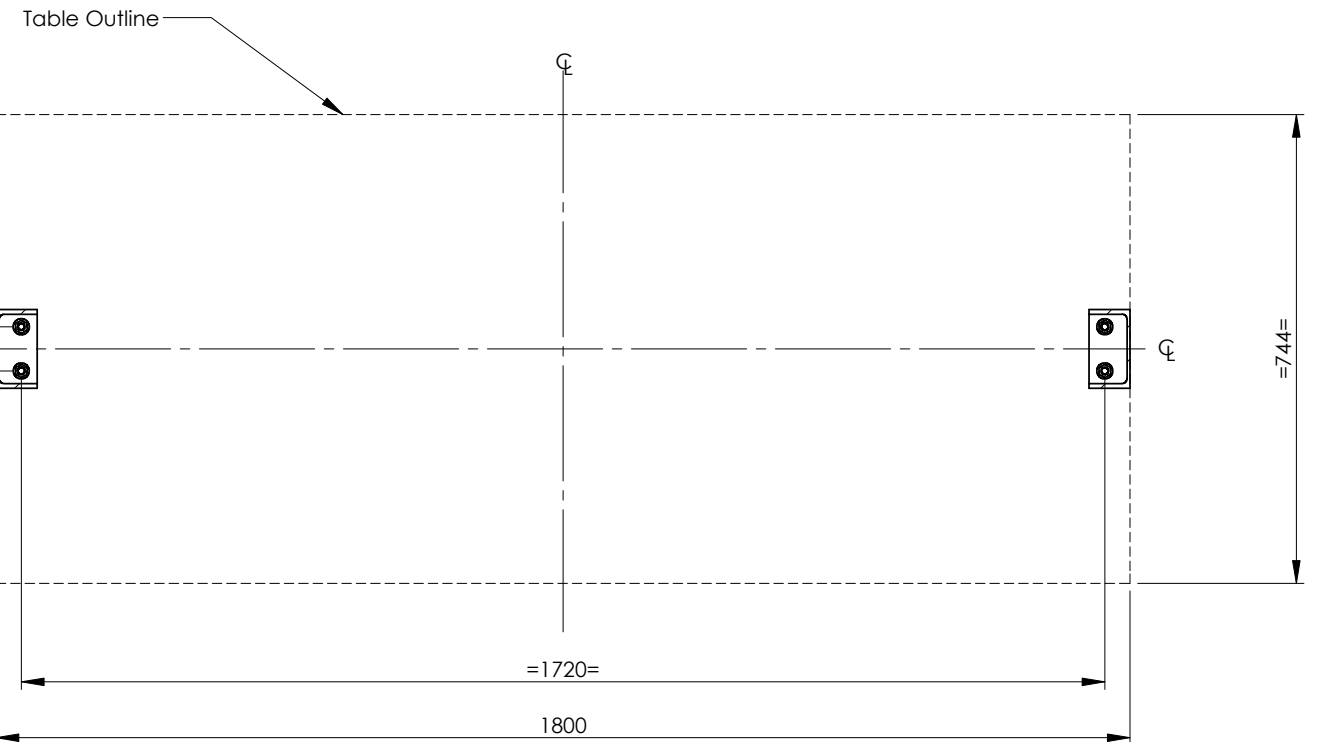

DETAIL C
SCALE 1 : 2

- GENERAL NOTES:
- All dimensions in millimetres unless otherwise shown.
 - Linear Tolerances:
 x ± 1.0
 x.x ± 0.5
 x.xx ± 0.1
 Angular Tolerances:
 ±0.5°
 - No deviation from drawing will be accepted without prior written approval.
 - Do not scale from drawings. Use dimensions provided if this is insufficient or ambiguous contact Mos for clarification

Title:
Surface Installation
Product:
Sturt Table
Dwg No: 1046-702 Date Drawn: 27/10/2018 Sheet No: 1 of 1 Scale: 1:12 Sheet: A3



PARTS LIST			
NO.	TITLE	MATERIAL	QTY.
1	Sturt Narrow Bench GA		1
2	Threaded Rod M12x160	Stainless Steel	4
3	Hex Nut-M12	Stainless Steel	12
4	Washer-M12	Stainless Steel	8

ISSUE	DESCRIPTION	DRAWN	DATE
A	Initial Release	TW	21/06/2018
B	changed leg	TW	24/10/2018

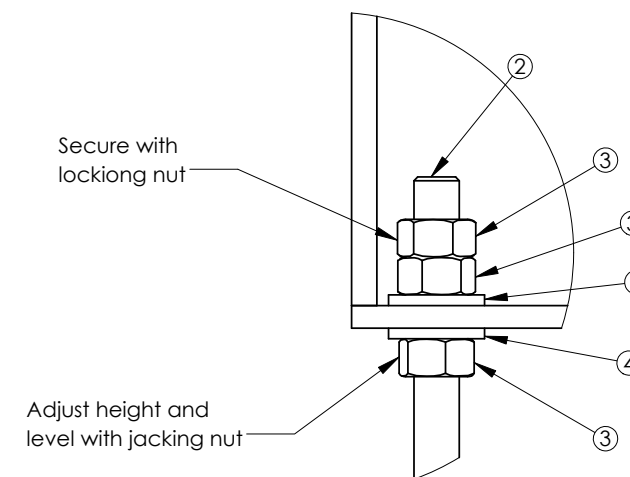
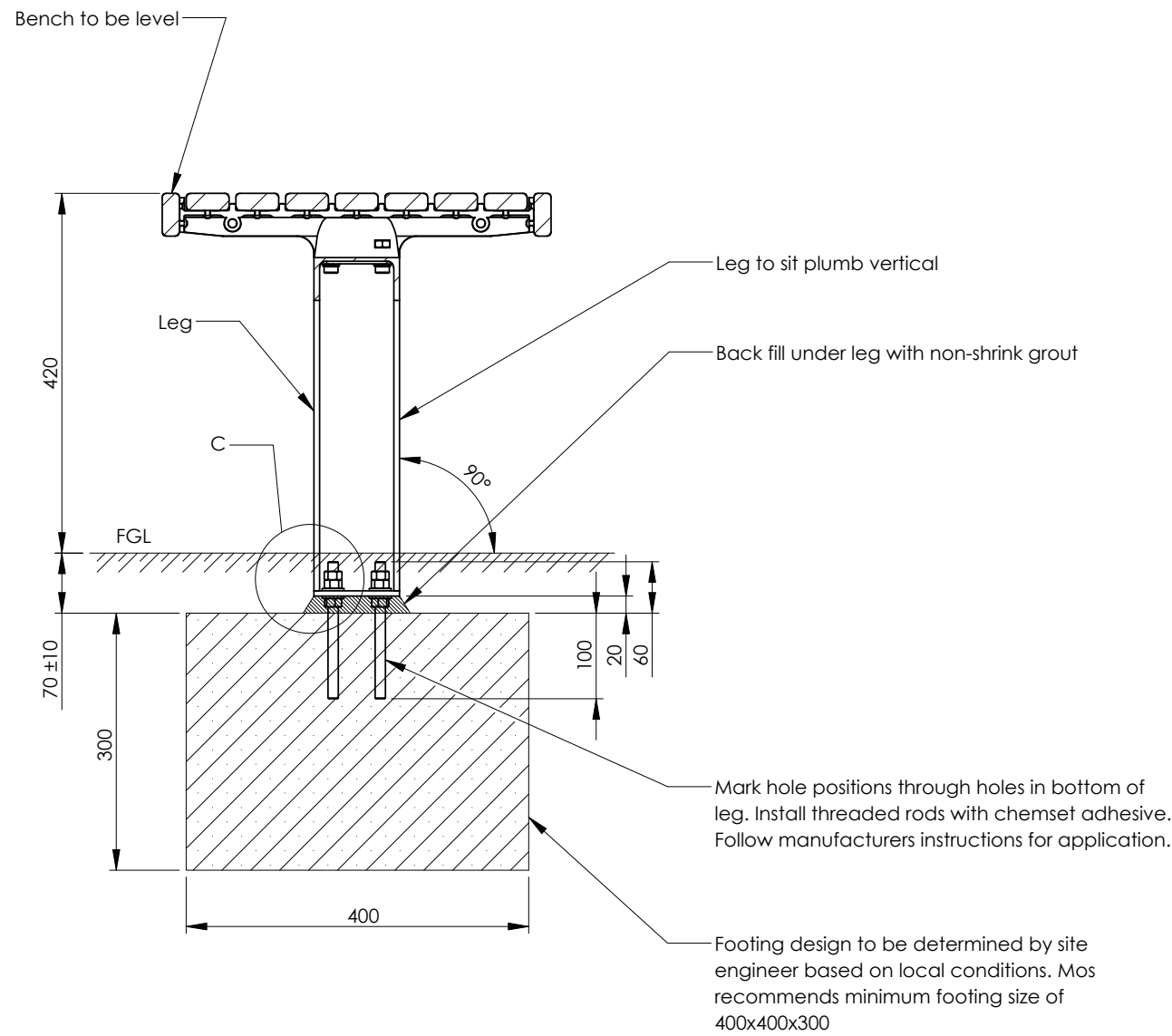
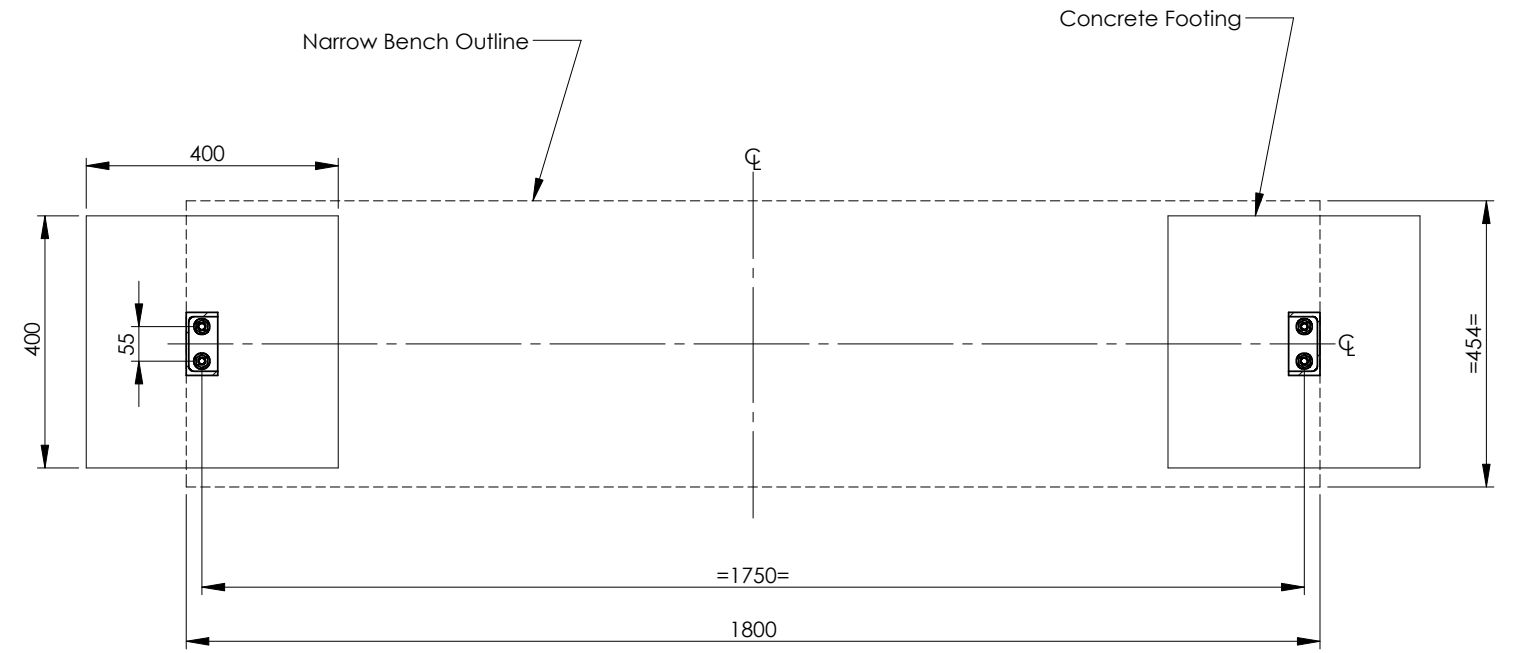

- GENERAL NOTES:**
- All dimensions in millimetres unless otherwise shown.
 - Linear Tolerances:
 x ± 1.0
 x.x ± 0.5
 x.xx ± 0.1
 Angular Tolerances:
 ±0.5°
 - No deviation from drawing will be accepted without prior written approval.
 - Do not scale from drawings. Use dimensions provided if this is insufficient or ambiguous contact Mos for clarification

Title:
Subsurface Installation
Product:
Sturt Narrow Bench
Dwg No: 1046-703 Date Drawn: 27/10/2018 Sheet No: 1 of 1 Scale: 1:12 Sheet: A3



PARTS LIST			
NO.	TITLE	MATERIAL	QTY.
1	Sturt Table GA		1
2	Threaded Rod M12x160	Stainless Steel	4
3	Hex Nut-M12	Stainless Steel	12
4	Washer-M12	Stainless Steel	8

ISSUE	DESCRIPTION	DRAWN	DATE
A	Initial Release	TW	21/06/2018
B	changed leg	TW	24/10/2018

Table to be level

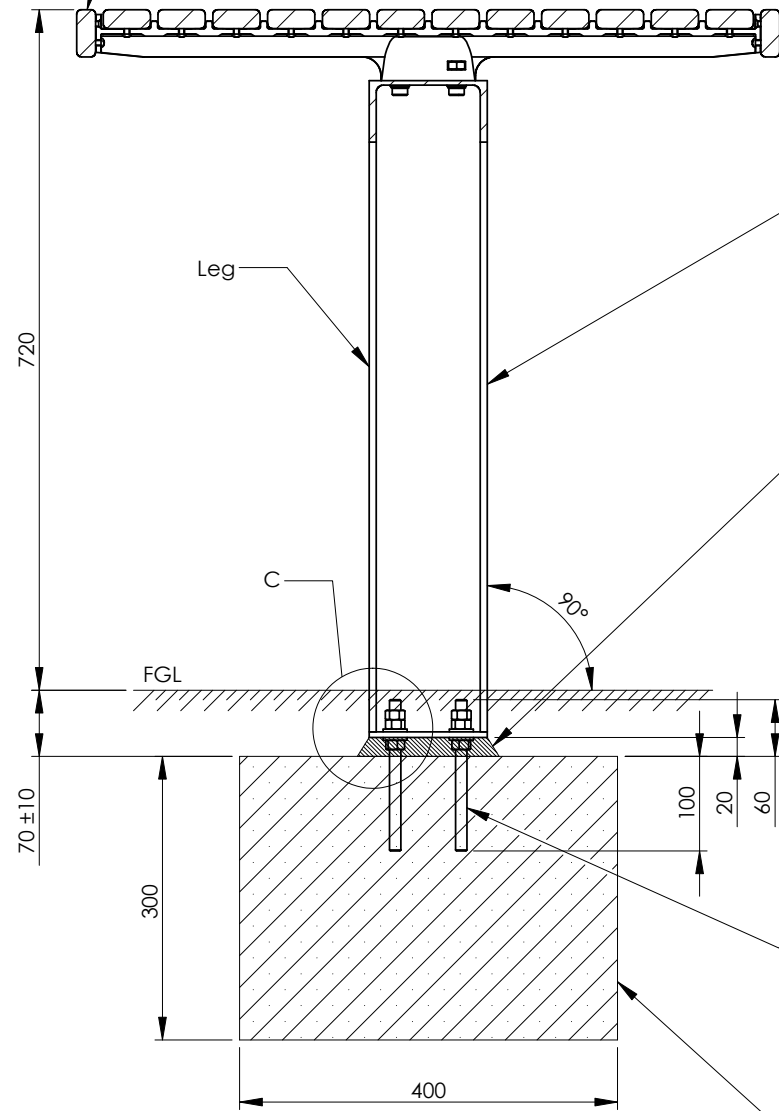

Leg to sit plumb vertical

Leg

Back fill under leg with non-shrink grout

90°

FGL

Mark hole positions through holes in bottom of leg. Install threaded rods with chemset adhesive. Follow manufacturers instructions for application.

Footing design to be determined by site engineer based on local conditions. Mos recommends minimum footing size of 400x400x300

Table Outline

Concrete Footing



Secure with locking nut

Adjust height and level with jacking nut

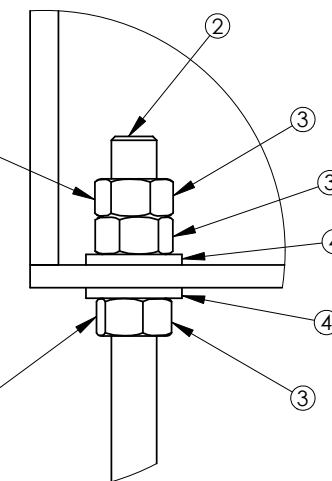

DETAIL C
SCALE 1 : 2

- GENERAL NOTES:
- All dimensions in millimetres unless otherwise shown.
 - Linear Tolerances:
 x ± 1.0
 x.x ± 0.5
 x.xx ± 0.1
 Angular Tolerances:
 ±0.5°
 - No deviation from drawing will be accepted without prior written approval.
 - Do not scale from drawings. Use dimensions provided if this is insufficient or ambiguous contact Mos for clarification

Title:
Subsurface Installation
Product:
Sturt Table

Dwg No: 1046-704 Date Drawn: 27/10/2018 Sheet No: 1 of 1 Scale: 1:12 Sheet: A3

MOS[®]
www.mosurban.com

Part Name:
Sturt Table Installation

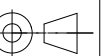

*NOTE: REFER TO 1046-701, 702, 703 and 704 FOR NARROW BENCH AND TABLE INSTALLATION DETAILS

ISSUE	DESCRIPTION	DRAWN	DATE
A	Initial Release	TW	22/06/2018

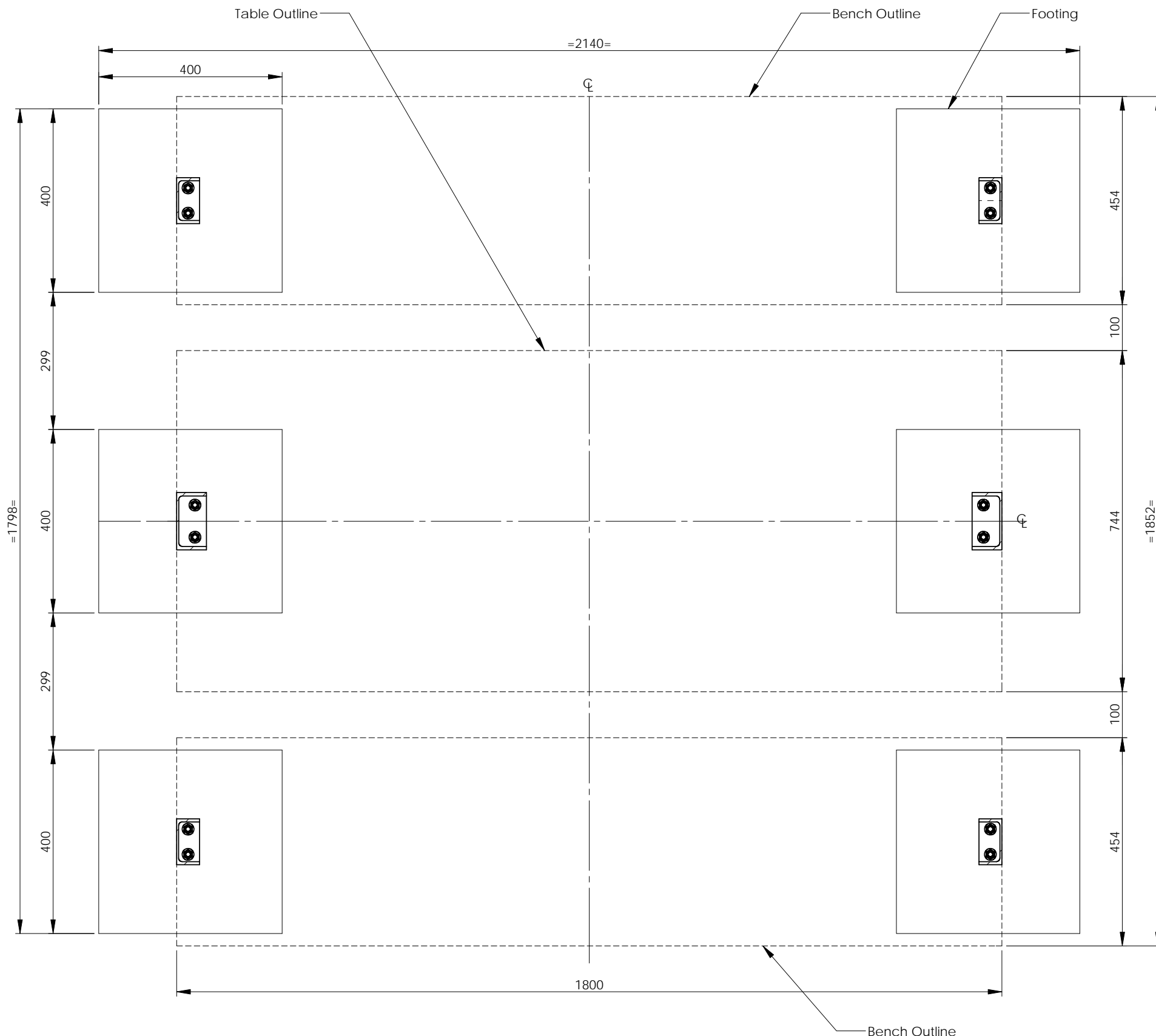

- GENERAL NOTES:
- All dimensions in millimetres unless otherwise shown.
 - Linear Tolerances:
 x ± 1.0
 x.x ± 0.5
 x.xx ± 0.1
 Angular Tolerances:
 ±0.5°
 - No deviation from drawing will be accepted without prior written approval.
 - Do not scale from drawings. Use dimensions provided if this is insufficient or ambiguous contact Mos for clarification.

Title:
 Footing Layout
 Product:
 Sturt Picnic Set

Dwg No: 1046-705 Date Drawn: 22/06/2018 Sheet No: 1 of 1 Scale: 1:10 Sheet: A3

